

## SPECIFICATION SHEET

**TYPE:** The Crane shall be a fold a way bumper mounted type, for mounting to vehicles 80" to 102" in width. (3) (shall be custom built to the vehicles width)

**CAPACITY:** The Crane shall have a designated lifting capacity of 2000 lbs.

**BOOM HEIGHT:** (1) The Boom shall have two fixed positions with an overall height of 77" and 85" from the top of the bumper.

**BOOM LENGTH:** (2) The Boom shall have a fixed length of 45".

**ALUMINUM COVER:** The Bumper shall have a two (2)-piece Aluminum Diamond Plate Cover, with a continuous stainless steel hinge attached with stainless steel rivets and a magnetic latch to secure the cover when closed.

**STEPS:** The Step shall consist of two (2) individual steps mounted flush with the bottom of the bumper. The Steps shall be positioned so as not to interfere with the hitch. The surface of the step to be grip strut and bolted to the bumper frame.

**IDENTIFICATION LAMPS:** Three (3) sealed beam LED lights shall be flush mounted in a heavy-duty rubber grommet in the upper center of the bumper. (Bumpers 80" or wider only)

**ROTATION:** The Crane shall have a 360-degree continuous manual rotation on machined surfaces, with two needle bearings and one thrust bearing that are environmentally sealed.

**HOIST:** The Hoist Motor shall be 12 volt D.C. powered, with a dual internal breaking system. Hoist shall have power up and power down.

**CABLE:** (6) The Cable shall be 35' x 7/32" galvanized aircraft quality cable, with a single line breaking strength of 5600 lbs., and safety hook.

**CONTROL:** A Hand Held Pendant Control, 10 feet in length, shall be furnished for controlling the hoisting function and shall be 12 volt D.C. powered. Pendant Control shall be weather resistant, with a solid rubber grip.

**POWER SOURCE:** The Power Source shall be the vehicles own 12-volt D.C. battery.

**OUTRIGGER:** The Crane shall have a permanently attached swing down adjustable outrigger, to increase stability and reduce the loading to the vehicle's suspension.

**HITCH:** The Bumper shall have a factory installed Class 4 Receiver type hitch. This Hitch is rated at 10,000 lbs. of drawbar pull and 1,200 lbs. vertical Hitch load. (Vehicle's rated towing capacity may be less)

**MOUNTING:** The Crane shall be provided with all necessary wiring, brackets, fasteners, and hardware, for bolt on mounting to the vehicle's frame. Note: Mounting to custom bodies or modified frames may require adaptation of supplied mounting brackets.

**WIRING:** The Crane shall be pre-wired from the factory and tested. The Cranes entire electrical system shall be circuit breaker protected.

**SAFETY:** The Crane shall be designed and manufactured according to the applicable ANSI standards for mobile cranes. The Crane shall be clearly marked with Maximum Load & Warning Decals.

**MAN-LIFT:** The Crane shall be OSHA & ANSI compliant as a Man-Lift for Confined Space Activities when equipped with the optional WO-CSR Confined Space Rescue & Recovery System.

**CONSTRUCTION:** The Bumper shall be of 2" X 5" tubular steel construction. The Mast shall be seamless DOM tubing with strong back. The Boom shall be formed from one piece of 3/16" ASTM A572 Grade 50 High Tensile Steel. All Sheaves shall be steel with sealed roller bearings. All Sheave Pins shall be made from plated stress proof steel.

**DOCUMENTATION:** The Crane shall be furnished with detailed Installation Instructions, Operation and Safety Instructions, Parts List, and Maintenance Instructions.

**FINISH COATING:** The Crane shall be Powder Coating, semi-gloss black.

**WARRANTY:** Manufacturer shall warrant the materials and workmanship for a period of one year from the date of delivery (excluding lifting cable)

- |    |               |           |
|----|---------------|-----------|
| 1: | Boom Height   | 77" & 85" |
| 2: | Boom Length   | 45"       |
| 3: | Bumper Width  | 80"-102"  |
| 4: | Bumper Height | 11"       |
| 5: | Bumper Depth  | 18"       |
| 6: | Cable Length  | 35'       |

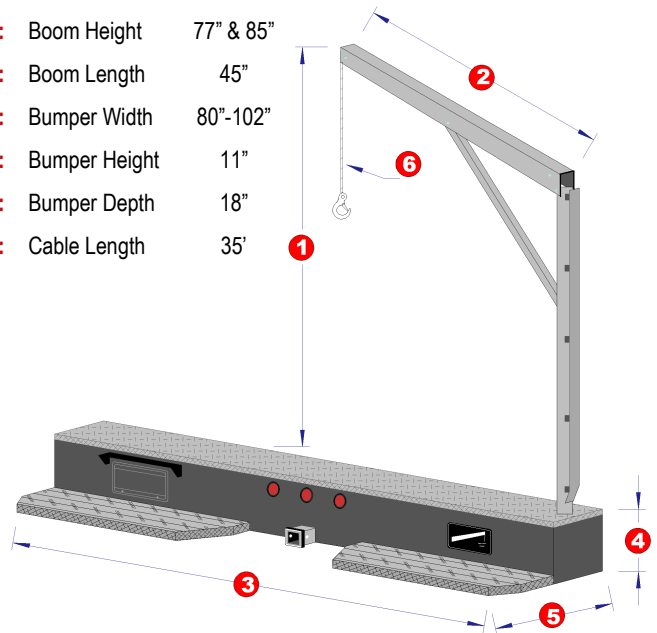

OPTIONS AND ACCESSORIES ARE AVAILABLE FOR THIS MODEL